

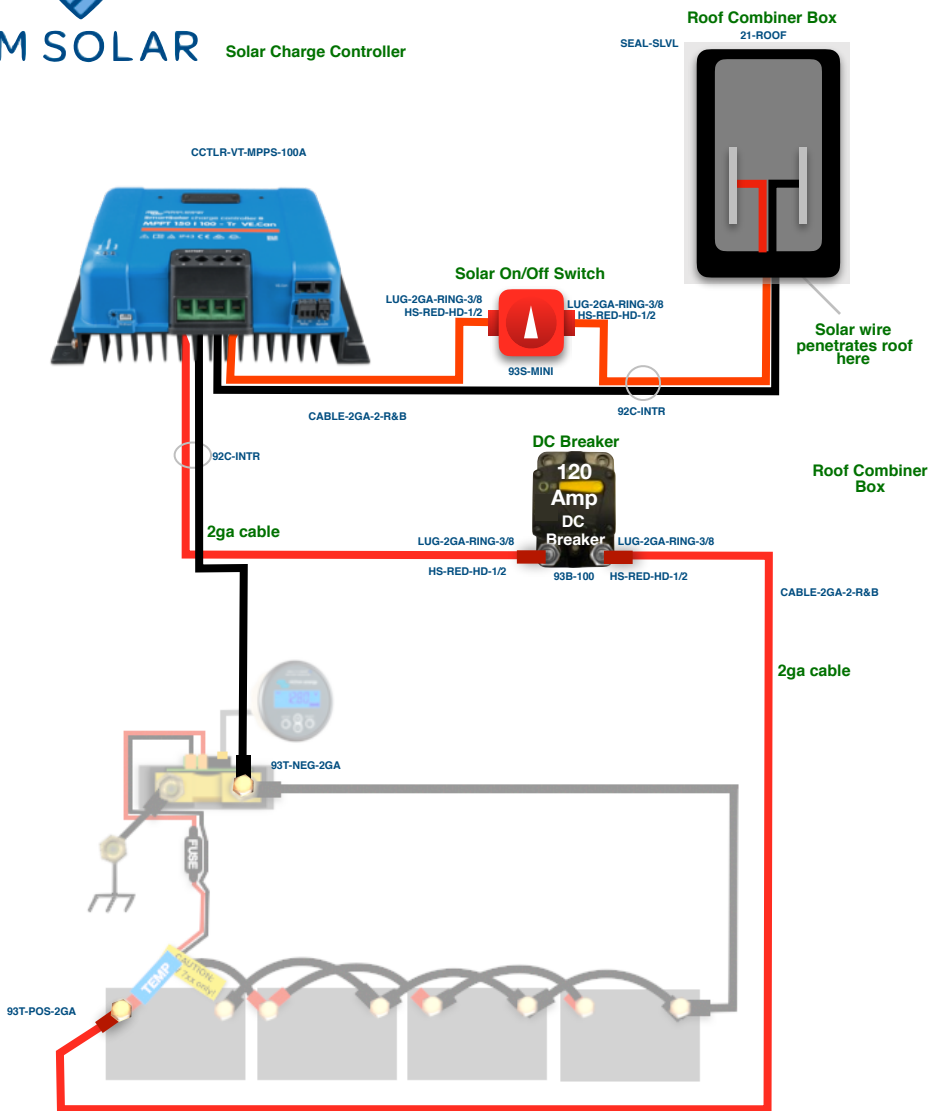

AM SOLAR Solar Charge Controller



This solar charging kit assumes individual solar panels, connected in parallel inside a combiner box to optimize partial shade performance. The output of the combiner box is routed to a master disconnect switch, then to an MPPT charge controller with Bluetooth programming and monitoring. The output of the charge controller is protected by a resettable breaker and fed onto the battery bank.

- Plan the placement of the components.** By using the cardboard boxes that the panels shipped in, you can strategize your optimum array layout and avoid shade from other roof-mounted obstructions. The combiner covers the roof penetration, so plan its placement with the wire route to the battery bay in mind. The charge controller should be mounted adjacent to or inside the same enclosure as your battery bank for temperature sensing. If this isn't possible, contact AM Solar for a remote temp sensor.
- Prep the panels by installing the output cable.** In some cases your panels may come shipped already prepped. The DIY INSTRUCTIONS page on our website will provide detailed instructions.
- Attach panel mounts** according the video on our website.
- Install the panels** according to the video on our website. On a metal roof, penetrations are rarely required. Don't let any part of the panel overhang the leading edge of the roof.
- Install the combiner box** by following the video instructions on our website. It's a good idea to check polarity before making any connections.
- Route the roof cable** from the combiner box, through the roof penetration down to the battery bay. Install the Master Disconnect switch with the switch in the OFF position and connect to the charge controller. It may be difficult to connect thick cables to the charge controller.
- Connect to the batteries** by routing a segment of remaining roof cable from the charge controller to the breaker to the battery bank.
- Permanently mount components** and verify all connections.
- Activate your solar charger** by turning on the breaker then the Master Disconnect switch. Skip ahead to the programming section of this manual to program the charge controller.

NOTICE:

The "greyed out" battery bank items are not included, but you will be interacting with them. For example purposes only.



CABLE OUTPUT INSTALLATION VIDEO

1



ROCKER FOOT MOUNT INSTALLATION VIDEO

2



SOLAR PANEL INSTALLATION VIDEO

3



ROOF COMBINER BOX INSTALLATION VIDEO

4



If the connections seem tight on the MPPT, that is normal. Scan here for assistance.

5

CAUTION:

There should be no continuity between the negative cable from the roof and the negative cable from the charge controller. If they connect it will fail. Keep these isolated from each other.